

Chapter 19.130 MTMC
LANDSCAPE/IRRIGATION PERMIT
Guidelines for Preparing a
Landscape Plan

Landscape Plan Requirements:

- ❑ Scale: 1"= 20' or 1" = 30' unless otherwise approved (same scale as civil plan).
- ❑ Maximum sheet size 24" x 36" (same size as civil plan).
- ❑ The layout is consistent with grading and civil plans.
- ❑ Show hard features including:
 - ❑ Light standards
 - ❑ Fire hydrants
 - ❑ Utility vaults (above and underground)
- ❑ Use symbols to represent plant material to show location on site.
- ❑ Create a key or legend with the following information:
 - ❑ Existing trees to be retained
 - ❑ All plant material labeled by botanical and common names
 - ❑ Container size, caliper or height (as appropriate)
 - ❑ Spacing of plant material
 - ❑ Quantity of each plant material (by number of plants or square feet of coverage)
- ❑ Planting details:
 - ❑ Trees (see Chapter 19.130 MTMC for spacing and caliper sizes):
 - ❑ Shrubs (minimum height of 21". See MTMC 19.130.110.B.3 for specific details)
 - ❑ Ground cover - typical spacing (see MTMC 19.130.110.B.4 for specific details):
 - 2" pots: 12" o.c.
 - 4" pots: 18" o.c.
 - 1 gallon containers: 30" o.c.
- ❑ Lawn grasses (see MTMC 19.130.110.B.5 for specific details).

Notes:

1. Refer to MTMC 19.130.040, MTMC 19.130.110 and MTMC 19.130 Article V (200-240).
2. Changes to issued plans may be considered. This can be done by submitting a written request prior to making any changes or substitutions to the approved landscape and irrigation plans. The developer/owner/applicant and the designer of the landscape plan must be in agreement on the changes. Request forms are available at City. Approval is at the discretion of the City.
3. In addition to the Landscape/Irrigation permit, the following permits may also apply.
 - a. Electrical Permit (low voltage wiring for irrigation)
 - b. Irrigation Permit (for separate meter required)

**Chapter 19.130 MTMC
LANDSCAPE/IRRIGATION PERMIT
Guidelines for Preparing an
Irrigation Plan**

Irrigation Plan Requirements:

- ❑ Scale: 1" = 20' or 1" = 30' unless otherwise approved
- ❑ Maximum sheet size: 24" by 36"
- ❑ Size and location of water meter(s)
- ❑ Static water pressure from City's water main
- ❑ Service line type, size, and length
- ❑ Type and location of drain(s), coupler(s), shut-off and control valve(s), controller(s), and backflow prevention device(s)
- ❑ Spatial layout of piping
- ❑ Main and lateral pipe size(s) and type(s)
- ❑ Performance chart showing type, series, and hydraulic characteristics (gpm) of sprinkler heads
- ❑ Hydraulic circuit analysis chart showing volume flow per valve
- ❑ City point of connection (POC) detail
- ❑ Installation details (include depth of burial for main and lateral lines)

Notes:

1. Refer to MTMC 19.130.040 and 120.
4. In addition to the Landscape/Irrigation permit, the following permits may apply.
 - a. Electrical Permit (low voltage wiring for irrigation)
 - b. Irrigation Permit (for separate meter required)

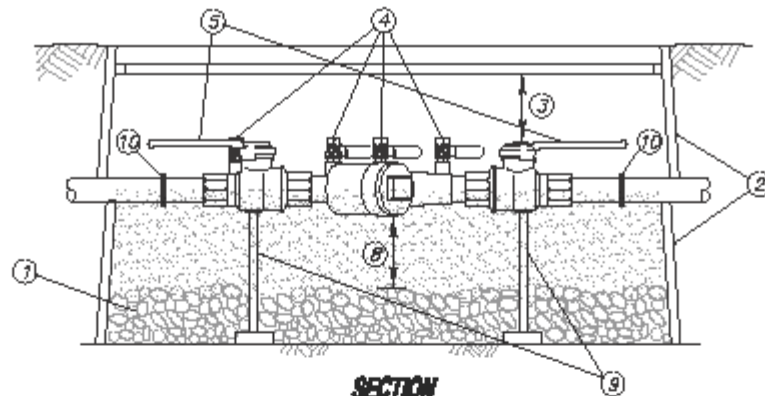

SECTION

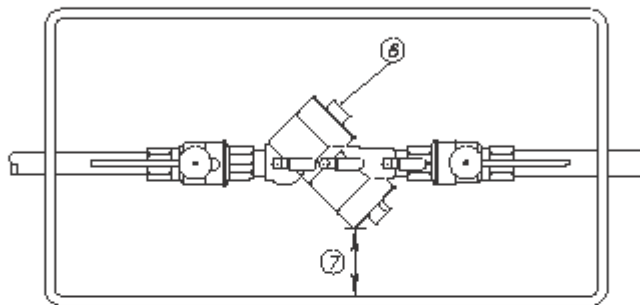

PLAN

DETAIL NOTES:

- ① IF DAYLIGHT DRAIN SYSTEM CANNOT BE PROVIDED THEN INSTALL A 6" MIN. LAYER OF 1" ROUND WASHED GRAVEL AT THE BOTTEM OF THE BOX.
- ② TWO NO. 2 METER BOXES STACKED ON TOP OF EACH OTHER OR APPROVED EQUAL.
- ③ A MAX. DISTANCE OF 12" BETWEEN THE UNDERSIDE OF THE LID AND THE HIGHEST POINT OF THE DEVICE IS REQUIRED.
- ④ THE DEVICE MUST BE EQUIPED WITH FOUR RESILIENT SEATED TEST COCKS WITH PLUGS INSTALLED. THE ASSEMBLY MUST ALSO BE INSTALLED WITH THE TEST COCKS FACING UP OR TO ONE SIDE.
- ⑤ THE DEVICE MUST ALSO BE EQUIPED WITH TWO RESILIENT SEATED SHUT OFF VALVES.
- ⑥ THE DEVICE MUST BE INSTALLED HORIZONTALLY.
- ⑦ A MIN. DISTANCE OF 6" BETWEEN THE SIDE OF THE BOX AND THE TEST COCKS WHEN THEY ARE INSTALLED SIDE WAYS.
- ⑧ A MIN. DISTANCE OF 1' BETWEEN THE LOWEST POINT OF THE ASSEMBLY AND THE DRAIN ROCK, FILLED WITH FINE BARK OR SANDUST TO PROVIDE FREEZE PROTECTION.
- ⑨ SUPPORTS WILL BE REQUIRED ON 2" DEVICES AS SHOWN.
- ⑩ UNION FOR EASE OF REMOVAL, OPTIONAL.

NOTES:

1. THE D.C.V.A. CHOSEN MUST BE ON THE MOST RECENT WASHINGTON STATE APPROVAL LISTING.
2. THE D.C.V.A. MUST BE TESTED BY A WASHINGTON STATE CERTIFIED BACKFLOW ASSEMBLY TESTER AT THE TIME OF INSTALLATION...ANNUALLY...AND WHEN MOVED OR REPAIRED.
3. ALL INSTALLATION MUST MEET MANUFACTURES SPECIFICATIONS AND THE MINIMUM STANDARDS OF THE U.P.C.



DWG TITLE:
Double Check Valve Assembly
 Irrigation or Domestic, 3/4" TO 2"
 SCALE: N.T.S.

PLAN No.
207B
 EFFECTIVE DATE:
 MARCH 2011

